

REPRINT

Roundabout metering signals: capacity, performance and timing

R. AKÇELIK

REFERENCE:

AKÇELIK, R. (2011). Roundabout metering signals: capacity, performance and timing. Paper presented at the *6th International Symposium on Highway Capacity and Quality of Service*, Transportation Research Board, Stockholm, Sweden.

NOTE:

This paper is related to the intersection analysis methodology used in the SIDRA INTERSECTION software.

Roundabout metering signals: capacity, performance and timing

Paper presented at the 6th International Symposium on Highway Capacity and Quality of Service, Transportation Research Board, Stockholm, Sweden, 2011.

Rahmi Akçelik

Abstract

Roundabout metering signals help to create gaps in the circulating stream to solve the problem of excessive queuing and delays caused by unbalanced flow patterns and high demand flow levels. This paper gives a brief summary of the control of roundabouts using metering signals and describes the basic concepts of an analytical model of the operation of roundabouts with metering signals. The model estimates capacities and performance measures (delay, queue length, stop rate, and so on) of the metered and controlling approaches of the roundabout as well as other approaches which operate as normal roundabout entries. Timing of roundabout metering signals is discussed and a case study is presented demonstrating the application of the model to a real-life roundabout in Melbourne, Australia, including consideration of alternative timing strategies.

1. Introduction

Roundabout metering signals have been used in Australia to create gaps in the circulating stream in order to solve the problem of excessive queuing and delays caused by unbalanced flow patterns and high demand flow levels. This is a cost-effective measure to avoid the need for a fully-signalized intersection treatment. The basic principles of the operation of roundabout metering signals have been explained, case studies have been presented and findings of a major research project on roundabouts controlled by metering signals have been discussed in previous papers by the author (Akçelik 2004, 2005a, 2006, 2008a). The case studies included one-lane, two-lane and three-lane roundabouts from Australia, UK and the USA with total intersection flow rates in the range 1700 to 5300 veh/h. The analyses were carried out using the SIDRA INTERSECTION micro-analytical software package (Akçelik and Associates 2010).

The reader is referred to papers by the author and others for related information on modeling of roundabouts without signals in general, and modeling of roundabouts with unbalanced flow conditions in particular (Akçelik 2003, 2005b, 2007, 2008b,c, 2009; Akçelik and Besley 2005; Akçelik, Chung and Besley 1997; Natalizio 2005; Huddart 1983; Krogscheepers and Roebuck 2000; O'Brien, et al 1997).

A brief summary of the operation of roundabout metering signals is described in *Section 2*. The basic concepts of an analytical model of the operation of roundabouts with metering signals are presented in *Section 3*. The basic relationships for timing analysis of roundabout metering signals are given in *Section 4*. A case study is introduced in *Section 3* to demonstrate the application of the model to a real-life roundabout in Melbourne, Australia. Model results for various timing strategies, including equal and unequal degrees of saturation (EQUISAT and non-EQUISAT), optimum cycle time based on a selected performance measure, and red and blank times for equal delay and equal queue length, applied to the case study are given in *Section 5*. The case study indicates benefits that can be obtained from the use of metering signals.

2. Operation of Roundabout Metering Signals

A brief summary of the operation of roundabout metering signals is given here.

Roundabout metering signals are installed on selected roundabout approaches and used on a part-time basis since they are required only when heavy demand conditions occur during peak periods. A typical arrangement for roundabout metering signals and an example from Melbourne, Australia (Akçelik 2006) is shown in *Figure 1* (picture modified to show driving on the right-hand side of the road).

The term *Metered Approach* is used for the approach stopped by red signals (approach causing problems for a downstream approach), and the term *Controlling Approach* is used for the approach with the queue detector, which is the approach benefited by metering signals.

When the queue on the Controlling approach extends back to the queue detector, the signals on the Metered approach display red (subject to signal timing constraints) so as to create a gap in the circulating flow. This helps the Controlling approach traffic to enter the roundabout. When the red display is terminated on the Metered approach, the roundabout reverts to normal operation.

The introduction and duration of the red signal on the Metered approach is determined by the Controlling approach traffic. The duration of the blank signal is determined according to a minimum blank time requirement, or extended by the metered approach traffic if detectors are used on that approach.

Two-aspect yellow and red signals are used for metering signals. The sequence of aspect display is Off to Yellow to Red to Off. When metering is not required neither aspect is displayed. Various site-specific methods may also be used to meter traffic, e.g. using an existing upstream midblock signalized crossing on the metered approach.

The Australian Traffic Signal Guide (AUSTROADS 2003) recommends the use of a minimum of two signal faces, one primary (signal face mounted on a post at or near the left of the stop line on the approach) and one tertiary (signal face mounted on a post on the downstream side to the left of that approach) for driving on the left-hand side of the road. A regulatory sign STOP HERE ON RED SIGNAL is fixed to any signal post erected adjacent to the stop line on the Metered approach, as drivers do not expect to stop at the advance stop line location.

The stop line on the Metered approach is located not less than 3 m / 10 ft in advance of the give-way / yield line but is preferably positioned approximately 20 m / 70 ft from the give-way (yield) line. Queue detector setback distance on the controlling approach is usually in the range 50-120 m / 150-400 ft.

In some cases, it may be necessary to supplement the traffic signals with explanatory fixed or variable message signposting. Where sight restrictions exist, advance warning signals are considered.

3. An Analytical Model of Roundabout Metering Signals

The basic concepts of an analytical model of the operation of roundabouts with metering signals are presented here. The method is available in the SIDRA INTERSECTION software package.

The method used for this purpose includes elements of both traffic signal and roundabout modeling with some special features for this intersection type. Essentially, an unsignalized roundabout model is used for capacity estimation, and then roundabout capacity values are used as signal saturation flow rates where required for capacity, performance and timing calculations. Capacities and performance measures (delay, queue length, stop rate, and so on) of the Metered and Controlling approaches of the roundabout as well as other approaches which operate as normal roundabout entries are estimated.

Special considerations apply to slip lanes and short lanes on Metered approaches, which affect timing, capacity and performance models for roundabout metering. The capacity and performance values of slip lane and short lane movements on Controlling and other non-metered approaches will also be affected by roundabout metering signals but there is no need for special treatment for these movements.

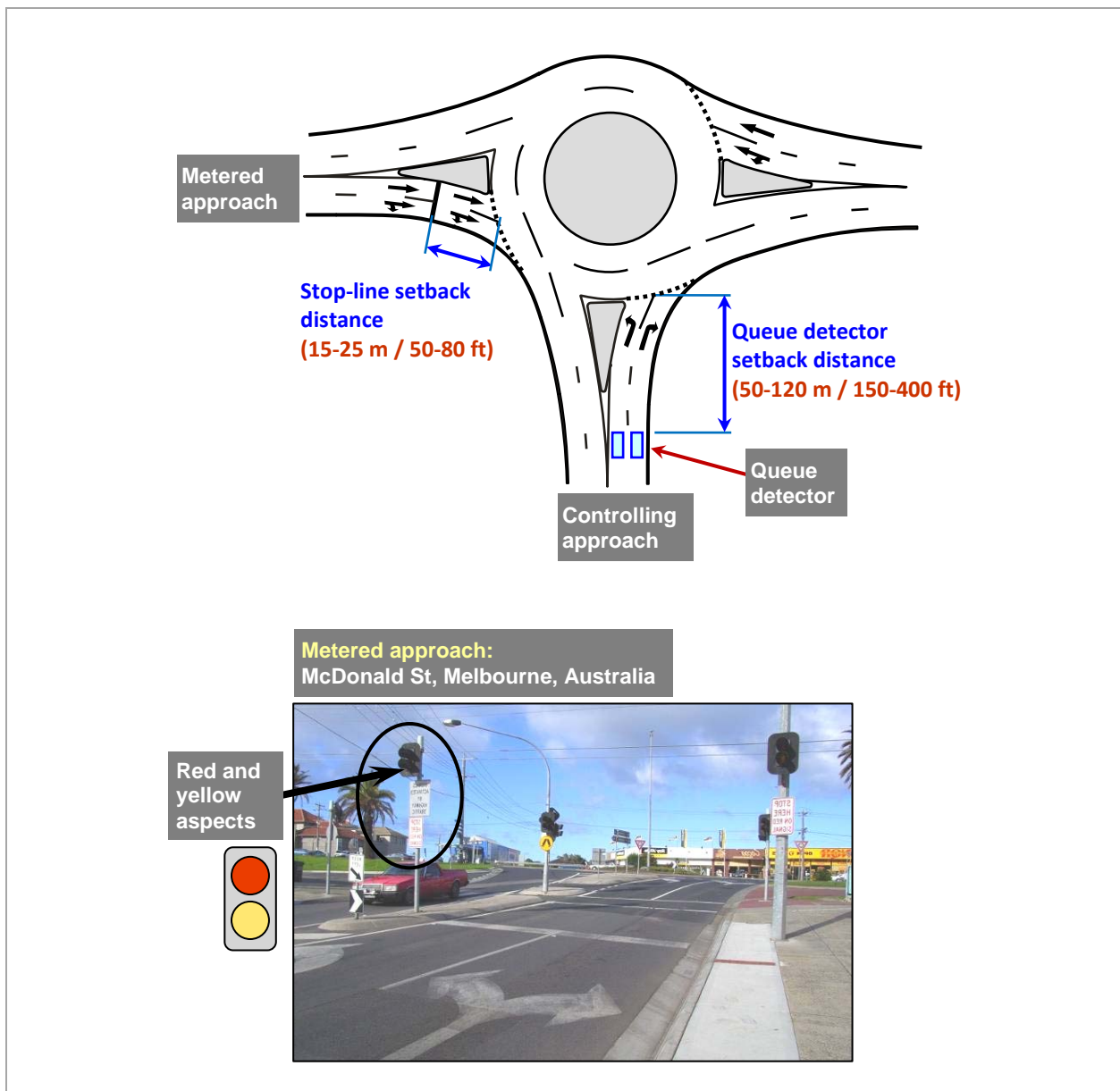

Figure 1 - Roundabout metering signals

In SIDRA INTERSECTION, the roundabout metering analysis method can be used with capacities estimated using the HCM 2010 / NCHRP 572 roundabout capacity model as well (Akcelik and Associates 2010).

Figure 2 shows the basic concept used in modeling Metered and Controlling (and other) approaches at roundabouts controlled by metering signals. Consideration of conditions during two distinct intervals, namely the Red and Blank intervals, forms the basis of the model.

In Figure 2, parameters $(sg)_1$ and $(sg)_2$ represent capacity per gap-acceptance cycle during Red and Blank signal intervals at Controlling or other non-metered approach lanes. The capacity per metering signal cycle for the metered approach is s_{MG_M} . In the simple construct shown in Figure 2, capacity of the controlling (or a non-metered) approach lane is seen to be $Q = (3600 / c_M) [n_{e1} (sg)_1 + n_{e2} (sg)_2] = (3600 / 95) \times [2 \times 4 + 3 \times 2] = 531 \text{ veh/h}$.

The example shown in Figure 3 will be used as a case study for roundabout metering signals (see Section 5). The treatment of Red and Blank signal conditions for this example is shown in Figure 4.

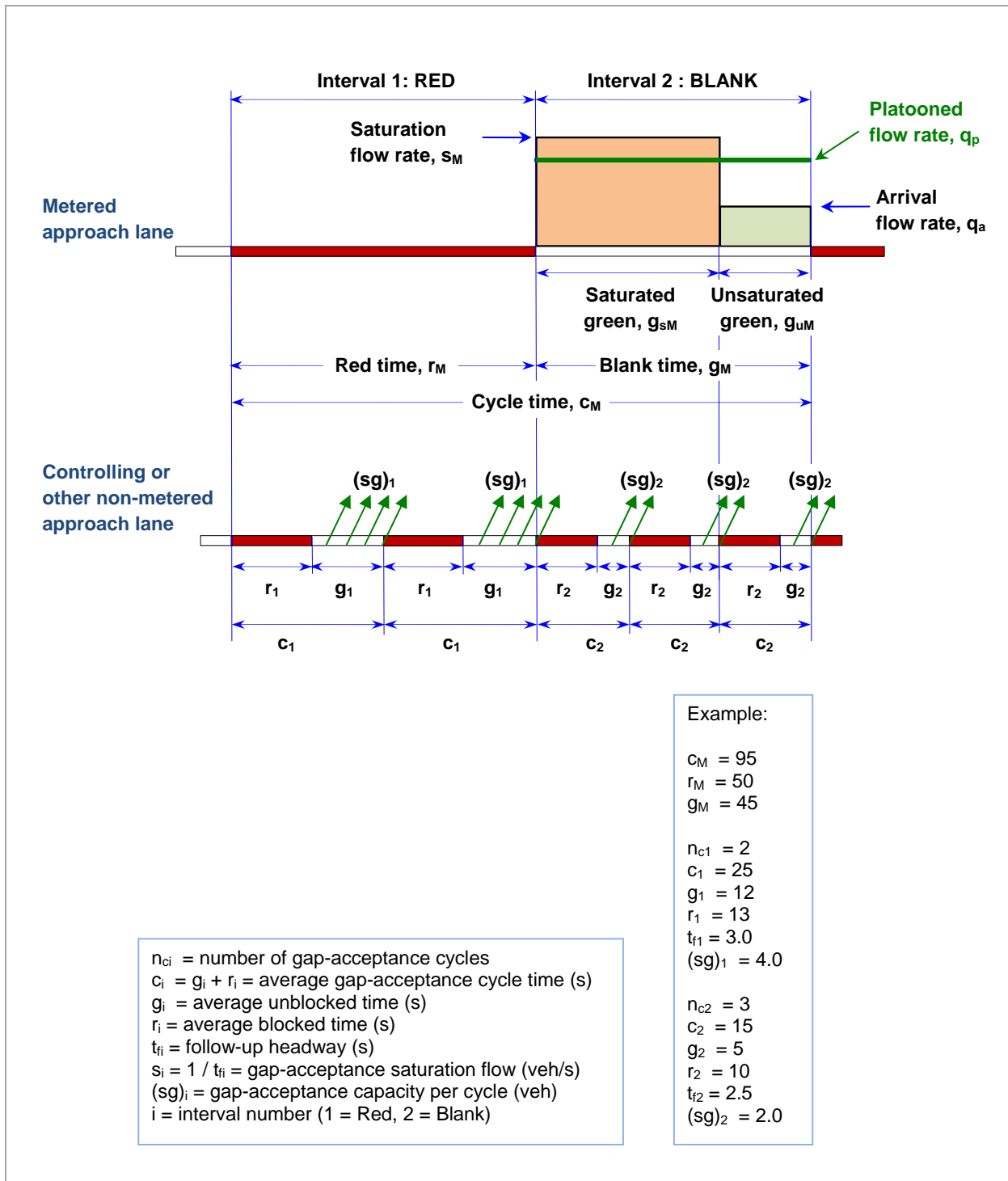
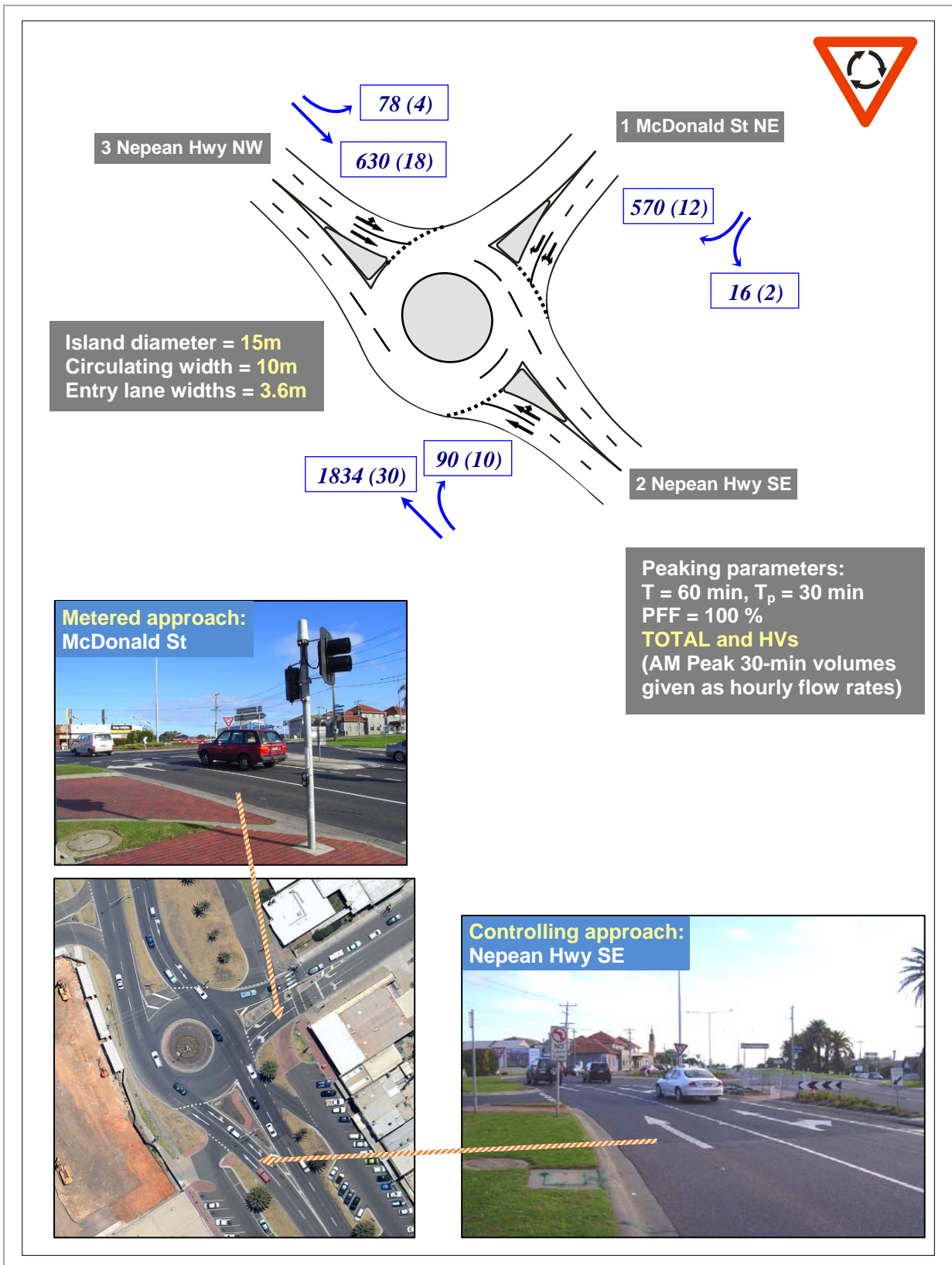

Figure 2 - The departure pattern and platooned arrival rate for a Metered approach lane during the Blank interval, and the gap-acceptance cycles for Controlling and other non-metered approaches during Blank and Red intervals



**Figure 3 - Roundabout metering signals case study:
Nepean Highway - McDonald Street, Mordialloc, Victoria, Australia**

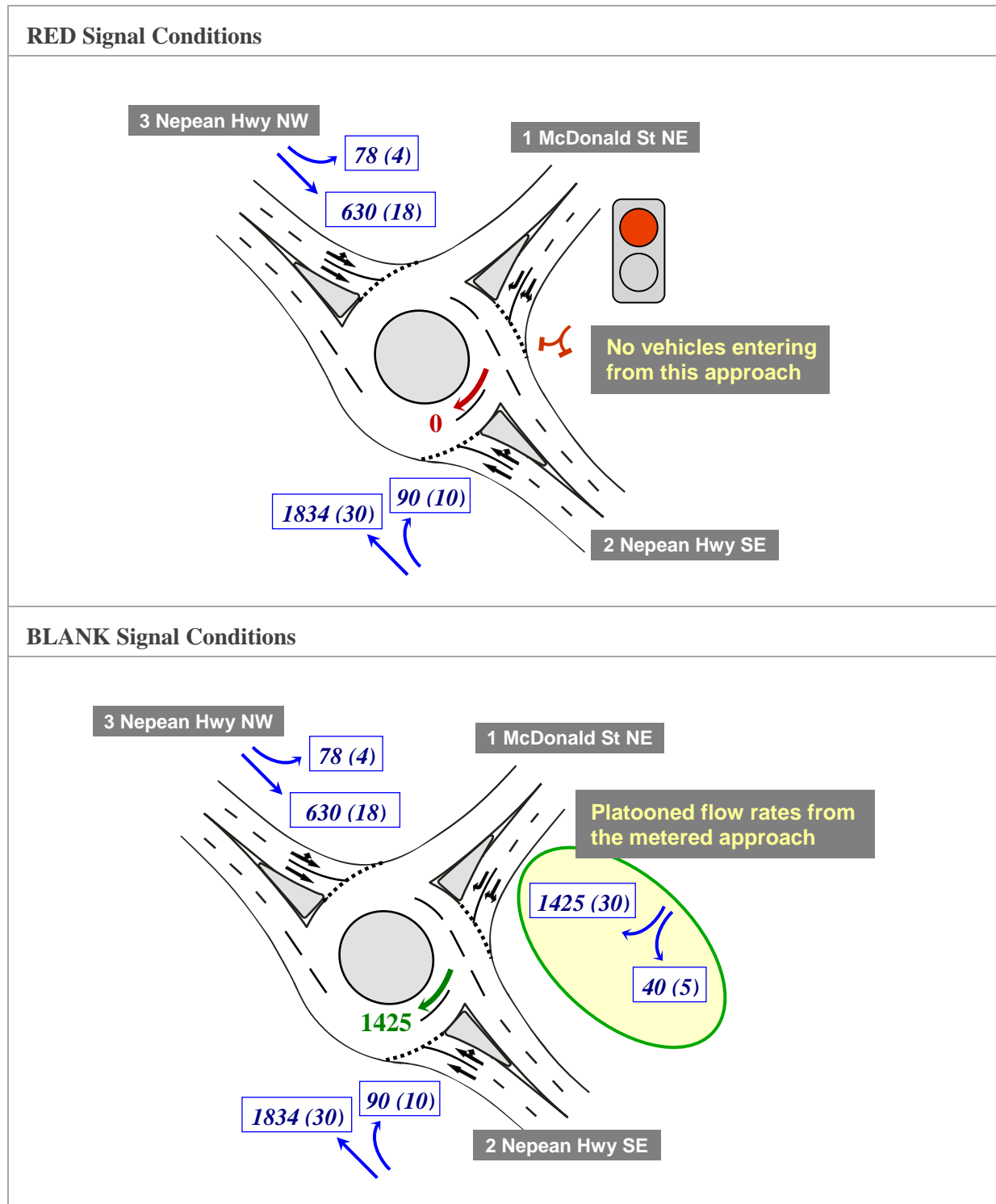

Figure 4 – Modeling of Red and Blank signal conditions

4. Timing Analysis of Roundabout Metering Signals

The timing analysis of roundabout metering signals is a simple application of the general signal timing methods used in SIDRA INTERSECTION (Akçelik 1981, Akcelik and Associates 2010). Alternative methods such as equal and unequal degrees of saturation and optimum cycle time based on various performance measures (e.g. minimum delay, minimum cost, etc) can be used.

Signal timing parameters for roundabout metering with Blank and Red phases as displayed at the Metered approach are shown in *Figure 5*. The parameters include the controller settings, displayed red and blank times as seen by drivers at the Metered approach, and effective red and green times as used in capacity and timing analysis for metered and controlling approach lanes.

The cycle time for roundabout metering signals is given by:

$$C_M = F_R + F_B = T_R + I_R + T_B + I_B = R_M + G_M + t_{yB} \quad (1)$$

where

T_R = Controller Red Time (controller setting which is different from the displayed red as seen by drivers),

T_B = Controller Blank Time (controller setting),

$F_R = T_R + I_R$ = Red Phase Time, and

$F_B = T_B + I_B$ = Blank Phase Time,

$R_M = t_{arB} + T_R + I_R$ = Displayed Red Time (as seen by drivers),

$G_M = T_B$ = Displayed Blank Time (as seen by drivers)

$I_R = t_{yR} + t_{arR}$ = Intergreen Time for the Red phase, and

$I_B = t_{yB} + t_{arB}$ = Intergreen Time for the Blank phase.

The minimum cycle time (sum of minimum phase times) is given by:

$$C_{Mmin} = F_{Rmin} + F_{Bmin} = T_{Rmin} + I_R + T_{Bmin} + I_B \quad (2)$$

The *effective* Red and Blank times (r_M , g_M) for the metered approach lanes are related to *displayed* Blank and Red times as follows:

$$r_M = R_M + t_{yB} + t_{sM} - t_{eM} = F_R + I_B + t_{sM} - t_{eM} \quad (3a)$$

$$g_M = G_M - t_{sM} + t_{eM} = T_B - t_{sM} + t_{eM} \quad (3b)$$

where t_{sM} and t_{eM} are the start loss and end gain values of the metered approach lanes (same for all lanes) specified as input values (default values = 3 s for both).

In the example shown in *Figure 5*, an end gain value of $t_{eM} = 4$ s has been chosen for the metered approach for the purpose of clearer depiction of the end gain values.

The cycle time using the effective red and green times (consistent with *Equation 1*) is:

$$C_M = r_M + g_M = R + G_M + t_{yBM} = F_R + T_B + I_B = F_R + F_B \quad (3c)$$

Effective minimum phase times and minimum cycle time values for timing calculations are:

$$r_{Mmin} = R_{Mmin} + t_{yB} + t_{sM} - t_{eM} = F_{Rmin} + I_B + t_{sM} - t_{eM} \quad (4a)$$

$$g_{Mmin} = G_{Mmin} - t_{sM} + t_{eM} = T_{Bmin} - t_{sM} + t_{eM} \quad (4b)$$

and the corresponding the minimum cycle time (consistent with *Equation 2*), is:

$$C_{Mmin} = r_{Mmin} + g_{Mmin} = F_{Rmin} + T_{Bmin} + I_B = F_{Rmin} + F_{Bmin} \quad (4c)$$

Further relationships are given in SIDRA INTERSECTION User Guide (Akcelik and Associates 2010).

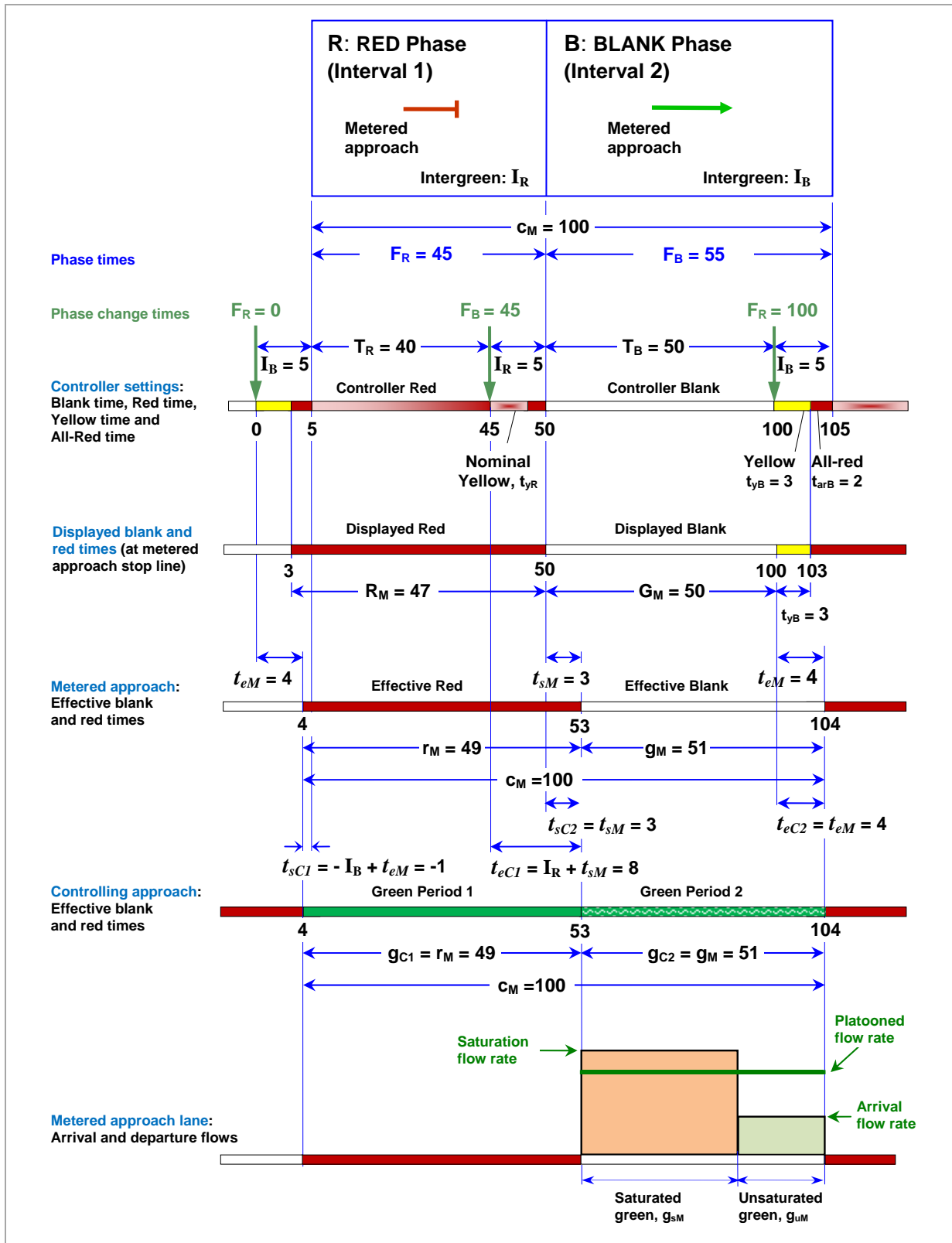

Figure 5 - Roundabout metering signals: timing relationships

5. Case Study

The results of analyses using SIDRA INTERSECTION for the example introduced in *Section 3* (Figures 3 and 4) are summarized in *Table 1*. This is the intersection of Nepean Highway and McDonald Street in Melbourne, Australia, which was used previously to demonstrate a method to model roundabout metering by employing several scenarios to represent different signal conditions at the roundabout (Akçelik 2006). The results given in *Table 1* are based on new method of modeling metering signals directly using SIDRA INTERSECTION Version 5.

In *Table 1*, the results are first given for the base case without the use of metering signals. It is seen that the SE approach (Nepean Hwy) is oversaturated while there is spare capacity (low degree of saturation) on the NE approach (McDonald St). These two approaches were chosen as Controlling and Metered for this reason.

In *Table 1*, results are then given for a number of alternative timings (durations of red and blank times) which correspond to different strategies, and therefore different types and levels of benefits to the Controlling approach, and different types and levels of disbenefit to the Metered approach. The timing options are explained below:

1. *Practical Cycle Time Using the EQUISAT Principle*: The timings are determined by the program using equal practical (target) degrees of saturation (85%) for the Controlling and Metered approaches. This is the default value of practical degree of saturation in SIDRA INTERSECTION. Note that the resulting degrees of saturation are not exactly equal due to rounding of red and blank times to nearest integer values. The effects of rounding also apply to other timing options below.
2. *Practical Cycle Time Using the Non-EQUISAT Principle*: The timings are determined by the program using practical degrees of saturation of 70% for the Metered approach and 85% for the Controlling approach, respectively. The lower practical degree of saturation was specified for the Metered approach to restrict the deterioration of conditions on this approach. This seems to be beneficial in general terms.
3. *Optimum Cycle Time (Minimum Delay or Minimum Cost)*: The timings are determined by the program. Cycle times which give minimum delay and minimum operating cost for the intersection were found (delay and operating cost selected as the performance measures). For this example, the same cycle time was found using these two performance measures. A low cycle time value was found. In this solution, the red and blank times are determined according to the EQUISAT principle.
4. *Cycle Time = 100 s Specified*: A longer cycle time compared with the cycle times found by SIDRA INTERSECTION was specified by the user. Red and blank times are determined by the program according to the EQUISAT principle. It is seen that the performances of both Metered and Controlling approaches are not as good as the lower cycle time solutions found by the program (options 1, 2 and 3).
5. *User Given Green Splits for Equal Delays ($c = 100$ s)*: The phase times are specified by the user. Red and blank signal durations were determined by trial and error to achieve equal average delay values for Metered and Controlling approaches. This achieves lower delay for the Metered approach by decreasing the duration of red signal.
6. *User Given Green Splits for Equal Delays ($c = 45$ s)*: The phase times are specified by the user as in option 5 but with a lower cycle time. This achieves better performance results compared with the longer cycle time in option 5.
7. *User Given Green Splits for Equal Queue Lengths ($c = 100$ s)*: The phase times are specified by the user. Red and blank signal durations were determined by trial and error to achieve equal queue length values for Metered and Controlling approaches.
8. *User Given Green Splits for Equal Queue Lengths ($c = 45$ s)*: The phase times are specified by the user as in option 7 but with a lower cycle time. Compared with option 7, shorter queue lengths are obtained due to the shorter cycle time but delay to the Metered approach is increased.

Table 2 gives yearly total values of various statistics corresponding to the alternative timing options in Table 1. These values correspond to one peak period only, and were calculated assuming those conditions to occur for 480 hours per year.

The results given in Tables 1 and 2 show that all timing strategies give significant benefits through the use of metering signals for this roundabout, and that timing strategies are available to limit disbenefits to the Metered approach.

6. Conclusion

The example given here reflects the general finding that the analytical model developed and incorporated into SIDRA INTERSECTION for estimating capacity and performance of roundabouts controlled by metering signals gives rather low cycle times for better intersection performance compared with longer cycle times used in practice for roundabouts controlled by metering signals. Research is recommended to test this finding at a number of real-life roundabouts.

Table 1 - Summary of roundabout metering analysis results for alternative timing options

Timing Method	Metered Approach (NE: McDonald St)						Controlling Approach (SE: Nepean Hwy)		
	Cycle Time (s)	Red Time (s)	Blank Time (s)	Deg. of Satn (v/c)	Aver. Delay (s)	Back of Queue (m)	Deg. of Satn (v/c)	Aver. Delay (s)	Back of Queue (m)
Base case: Without Roundabout Metering	NA	NA	NA	0.325	13.5	14	1.067	84.2	449
Timing Method									
1. Program Determined - Practical Cycle Time: EQUISAT	48	29	19	0.806	41.5	119	0.834	14.1	138
2. Program Determined - Practical Cycle Time: Non-EQUISAT	56	31	25	0.717	34.6	118	0.858	15.3	149
3. Program Determined - Optimum Cycle Time (Min. Delay or Min. Cost)	25	16	9	0.878	40.5	113	0.815	12.9	83
4. Program Determined - c = 100 User Given	100	61	39	0.825	60.9	219	0.831	12.2	158
5. User Given - Equal Delays (c = 100 chosen)	100	34	66	0.490	23.8	118	0.944	23.6	194
6. User Given - Equal Delays (c = 45 chosen)	45	17	28	0.514	20.1	68.6	0.929	20.4	160
7. User Given - Equal Queue Lengths (c = 100 chosen)	100	51	49	0.659	37.5	170	0.877	16.2	169
8. User Given - Equal Queue Lengths (c = 45 chosen)	45	29	16	0.895	56.5	129	0.813	13.3	124

Table 2 - Summary of total yearly values for the roundabout under alternative timing options

Timing Method	Metered Approach (NE: McDonald St)			Intersection (Total Yearly Values)				
	Cycle Time (s)	Red Time (s)	Blank Time (s)	Total Delay (pers-h/y)	Effective Stops (veh/y)	Operating Cost (\$/y)	Fuel Cons. (L/y)	CO2 (kg/y)
Base case: Without Roundabout Metering	NA	NA	NA	27,929	3,187,217	1,201,423	151,956	380,252
Timing Method								
1. Program Determined - Practical Cycle Time: EQUISAT	48	29	19	8,985	1,356,984	758,832	119,294	298,527
2. Program Determined - Practical Cycle Time: Non-EQUISAT	56	31	25	8,680	1,354,823	752,952	119,118	298,086
3. Program Determined - Optimum Cycle Time (Min. Delay or Min. Cost)	25	16	9	8,503	1,579,089	745,769	117,296	293,528
4. Program Determined - c = 100 User Given	100	61	39	10,206	1,175,250	786,213	120,046	300,411
5. User Given - Equal Delays (c = 100 chosen)	100	34	66	10,242	1,642,798	792,394	122,527	306,615
6. User Given - Equal Delays (c = 45 chosen)	45	17	28	8,910	1,650,813	760,739	120,133	300,626
7. User Given - Equal Queue Lengths (c = 100 chosen)	100	51	49	9,249	1,315,753	766,055	119,970	300,220
8. User Given - Equal Queue Lengths (c = 45 chosen)	45	29	16	10,143	1,436,587	784,399	120,818	302,342

7. References

AKCELİK and ASSOCIATES (2010). *SIDRA INTERSECTION User Guide (for Version 5.0)*. Akcelik and Associates Pty Ltd, Melbourne, Australia.

AKÇELİK, R. (1981). *Traffic Signals: Capacity and Timing Analysis*. Australian Road Research Board. Research Report ARR No. 123 (6th reprint: 1995).

AKÇELİK, R. (2003). A roundabout case study comparing capacity estimates from alternative analytical models. *2nd Urban Street Symposium*, Anaheim, California, USA.

AKÇELİK, R. (2004). Roundabouts with unbalanced flow patterns. *ITE Annual Meeting*, Lake Buena Vista, Florida, USA.

AKÇELİK, R. (2005a). Capacity and Performance Analysis of Roundabout Metering Signals. *TRB National Roundabout Conference*, Vail, Colorado, USA.

AKÇELİK, R. (2005b). Roundabout Model Calibration Issues and a Case Study. *TRB National Roundabout Conference*, Vail, Colorado, USA.

- AKÇELİK, R. (2006). Operating cost, fuel consumption and pollutant emission savings at a roundabout with metering signals. *ARRB 22nd Conference*, Canberra, Australia.
- AKÇELİK, R. (2007). A review of gap-acceptance capacity models. *29th Conference of Australian Institutes of Transport Research (CAITR 2007)*, Adelaide, Australia.
- AKÇELİK, R. (2008a). An investigation of the performance of roundabouts with metering signals. *National Roundabout Conference*, Transportation Research Board, Kansas City, MO, USA, May 2008.
- AKÇELİK, R. (2008b). Roundabouts in Australia. *National Roundabout Conference*, Transportation Research Board, Kansas City, MO, USA, May 2008.
- AKÇELİK, R. (2008c). The relationship between capacity and driver behaviour. *National Roundabout Conference*, Transportation Research Board, Kansas City, MO, USA, May 2008.
- AKÇELİK, R. (2009). Evaluating Roundabout Capacity, Level of Service and Performance. *ITE Annual Meeting*, San Antonio, Texas, USA.
- AKÇELİK, R. and BESLEY, M. (2005). Differences between the AUSTRROADS Roundabout Guide and aaSIDRA roundabout analysis methods. *Road & Transport Research* 14(1), pp 44-64.
- AKÇELİK, R., CHUNG, E. and BESLEY M. (1997). Analysis of Roundabout Performance by Modelling Approach Flow Interactions. In: Kyte, M. (Ed.), *Proceedings of the Third International Symposium on Intersections Without Traffic Signals*, July 1997, Portland, Oregon, USA, University of Idaho, Moscow, Idaho, USA, pp 15-25.
- AUSTRROADS (2003). *Guide to Traffic Engineering Practice Part 7 - Traffic Signals*. AP-G11.7. Association of Australian State Road and Transport Authorities, Sydney, Australia.
- NATALIZIO, E. (2005). Roundabouts with Metering Signals. *ITE Annual Meeting*, Melbourne, Australia.
- HUDDART, K.W. (1983). Signaling of Hyde Park Corner, Elephant and Castle and other roundabouts. *PTRC Summer Annual Meeting, Proceedings of Seminar K*, 1983, pp 193-208.
- KROGSCHEEPERS, J. C. and ROEBUCK, C. S. (2000). Unbalanced traffic volumes at roundabouts. *Fourth International Symposium on Highway Capacity*, Transportation Research Circular E-C018, Transportation Research Board, pp 446-458.
- O'BRIEN, A., AKÇELİK, R., WILLIAMSON, D. and PANTAS, T. (1997). Three-laning a two-lane roundabout - the outcomes. *ITE Annual Meeting*, Boston, Massachusetts, USA.